

FORGED HOOKS

Miller hooks are produced in accordance with the following DIN standards:

- DIN 15400- Lifting hooks, materials, mechanical properties, lifting capacity, stresses
- DIN 15401- Single hooks
- DIN 15402- Rams horn hooks (double hooks) with and without bottom hole
- DIN 7540- Eye hook class 8 (grade 80)



DIN is the German Institute for Standardization (Deutsches Institut für Normung) and has been based in Berlin since 1917. DIN has historically developed the detailed and exacting standards used in German engineering and is the body that represents Germany in international standards organizations.

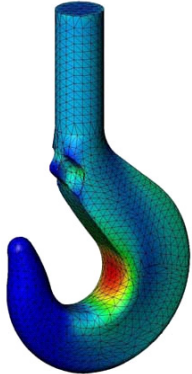

Shank Hooks

Hooks feature markings of fixed distances ("y" dimension) which allow confirmation that no deformation has occurred in use, under testing, etc. This dimension is a detail of the DIN requirement.

Hooks are identified by hook number and material. Each hook number maintains identical dimensions across a number of raw materials and has increasing load capacity depending on the material used. Hooks are forged and heat treated for optimal strength and toughness properties.

- Shank hook forgings are available in three increasingly stronger materials:
- DIN **class P**, fine-grained carbon steel. St-E355/St-E420, similar to ASTM A573 Gr. 65
 - DIN **class T**, alloy steel 34CrMo4-34CrNiMo6, similar to SAE 4135/4340
 - DIN **class V**, super alloy steel, 34CrNiMo6-30CrNiMo8, similar to SAE 4340/4337

In the following **selection tables** for shank hooks, three working load limits are indicated for each hook number depending on the material selected. Hook forgings have a design safety factor of 5. Safety latches are included. Longer shanks are available (dimension "B", +150 to +200mm).

Miller also offers **hook machining with matching nut** for your particular application from our stock of DIN hooks or from the hook manufacturer of your choice. This catalog includes hooks up to working loads of 500 metric tons. Please inquire for higher load requirements.

DIN HOOK NO.	FIXED DISTANCE MARKS "Y" FOR DEFORMATION INDICATION (MM)													
	6	8	10	12	16	20	25	32	40	50	63	80	100	125
SINGLE HOOKS	130	145	160	180	200	225	255	290	320	355	400	450	505	570
DOUBLE HOOKS	93	104.5	117.5	132.5	148.5	165.5	185	207	233	265	297	331	370	414.5

Eye Hooks

See detailed eye hook tables immediately following the shank hook tables.

Our **DIN 7540 Grade 80 Eye Hook** features the traditional eye-ring of circular cross section allowing the maximum degree of motion in the connection and is available standard in working load ratings up to metric 400 tons. These are forged from 34CrNiMo6V alloy steel with safety latch and can be adapted for ROV use. Design factor is 4:1.



Our **Shackle Eye Hook** features an eye of cylindrical section for a close fit onto the shackle pin, limiting motion and evenly distributing the load. These are similar to DIN 15401 shank hooks and are forged from the class V alloy steel material noted above. Design factor is 5:1. Our Shackle Eye Hooks include a locking safety latch and can also be adapted for ROV (remotely operated vehicle) use.

FORGED HOOKS- SINGLE HOOKS DIN 15401

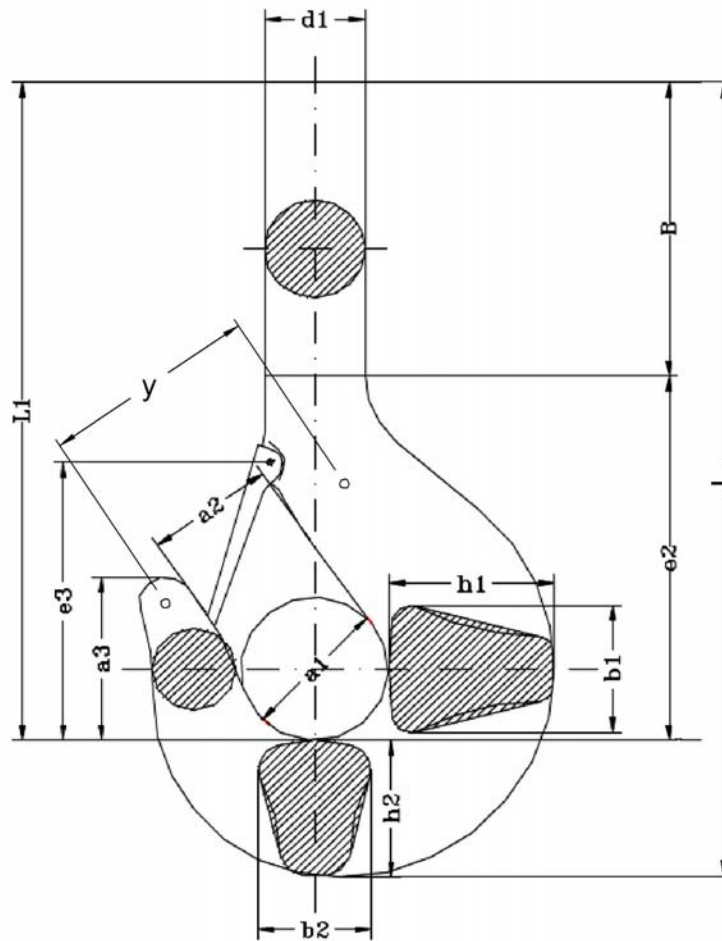

Model Number	Capacity Metric Tons Carbon Class P	Capacity Metric Tons Alloy Class T	Capacity Metric Tons Super Alloy Class V	a1	a2	a3	B	b1	b2	d1	e2	e3	h1	h2	L	L1	y	Weight Kg.
GS 1,6	3	5	6.5	56	45	64	78	45	38	36	146	118	56	48	272	224		4.5
GS 2,5	5	8	10	63	50	72	86	53	45	42	167	132	67	58	311	253		6.3
GS 4	8	12	16	71	56	80	95	63	53	48	190	148	80	67	352	285		8.8
GS 5	10	16	20	80	63	90	103	71	60	53	215	165	90	75	393	318		12.3
GS 6	12.5	20	25	90	71	101	140	80	67	60	240	185	100	85	465	380	130	17.1
GS 8	16	25	32	100	80	113	150	90	75	67	268	210	112	95	513	418	145	24
GS 10	20	32	40	112	90	127	166	100	85	75	286	221	125	106	558	452	160	34
GS 12	25	40	50	125	100	143	209	112	95	85	316	252	140	118	643	525	180	55
GS 16	32	50	63	140	112	160	238	125	106	95	357	280	160	132	727	595	200	77
GS 20	40	63	80	160	125	180	260	140	118	106	405	330	180	150	815	665	225	112
GS 25	50	80	100	180	140	202	280	160	132	118	455	360	200	170	905	735	255	160
GS 32	63	100	125	200	160	225	300	180	150	132	510	400	224	190	1000	810	290	220
GS 40	80	125	160	224	180	252	338	200	170	150	567	447	250	212	1117	905	320	310
GS 50	100	160	200	250	200	285	355	224	190	170	635	485	280	236	1226	990	355	430
GS 63	125	200	250	280	224	320	410	250	212	190	710	550	315	265	1385	1120	400	600
GS 80	160	250	320	315	250	358	468	280	236	212	802	598	355	300	1570	1270	450	860
GS 100	200	320	400	355	280	402	513	315	265	235	902	688	400	335	1750	1415	505	1220
GS 125	250	400	500	400	315	450	570	355	300	265	1020	750	450	375	1965	1590	570	1740

•Dimensions are in millimeters •Tolerance on all dimensions, +7/-0 %

FORGED HOOKS- DUPLEX HOOK DIN 15402

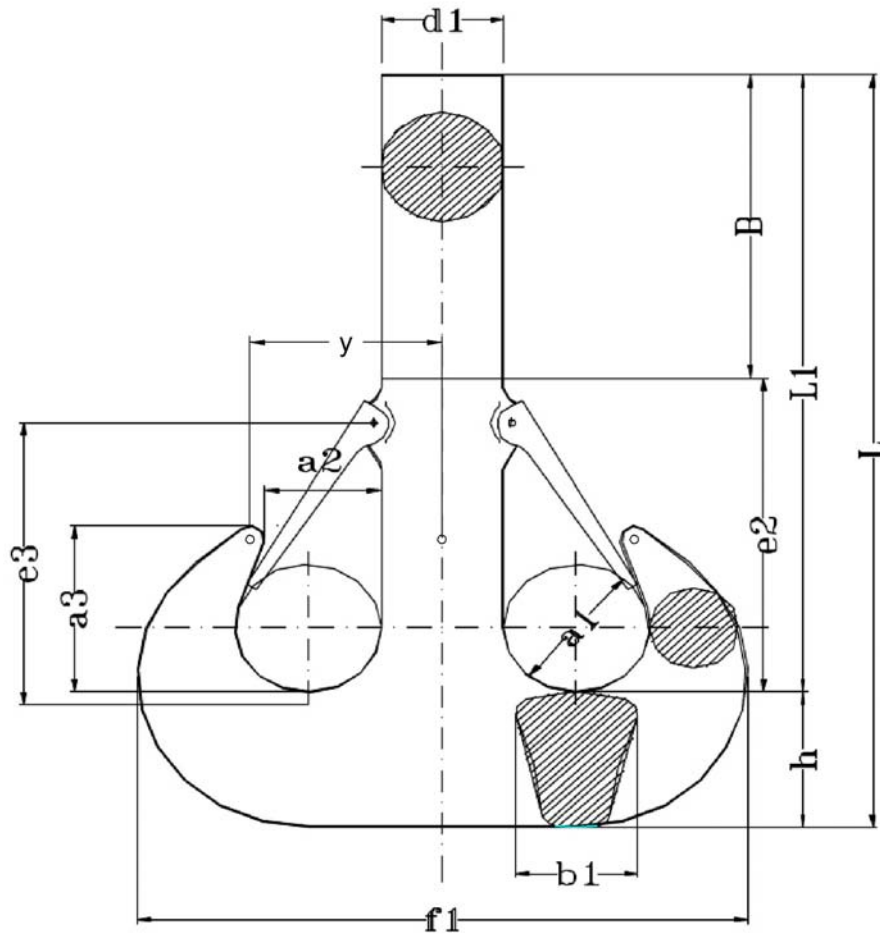

Model Number	Capacity Metric Tons Carbon Class P	Capacity Metric Tons Alloy Class T	Capacity Metric Tons Super Alloy Class V	a1	a2	a3	B	b1	d1	e2	e3	f1	H	L	L1	y	Weight Kg.
GD 6	12.5	20	25	71	56	92	183	60	60	192	160	301	75	450	375	93	16.8
GD 8	16	25	32	80	63	103	197	67	67	218	182	337	85	500	415	104.5	25.3
GD 10	20	32	40	90	71	116	220	75	75	230	192	377	95	545	450	117.5	35.3
GD 12	25	40	50	100	80	130	258	85	85	252	210	421	106	616	510	132.5	50
GD 16	32	50	63	112	90	146	296	95	95	284	237	471	118	698	580	148.5	71
GD 20	40	63	80	125	100	163	332	106	106	318	265	531	132	782	650	165.5	100
GD 25	50	80	100	140	112	182	347	118	118	378	315	598	150	865	715	185	138
GD 32	63	100	125	160	125	205	388	132	132	402	335	672	170	960	790	207	197
GD 40	80	125	160	180	140	230	435	150	150	450	375	754	190	1075	885	233	286
GD 50	100	160	200	200	160	260	461	170	170	504	420	842	212	1177	965	265	394
GD 63	125	200	250	224	180	292	538	190	190	552	460	944	236	1326	1090	297	547
GD 80	160	250	320	250	200	325	617	212	212	618	515	1062	265	1500	1235	331	760
GD 100	200	320	400	280	224	364	685	235	235	690	575	1186	300	1675	1375	370	1060
GD 125	250	400	500	315	250	408	776	265	265	774	645	1330	335	1885	1550	414.5	1491

•Dimensions are in millimeters •Tolerance on all dimensions, +7/-0 %

FORGED HOOKS- DUPLEX HOOK DIN 15402-B

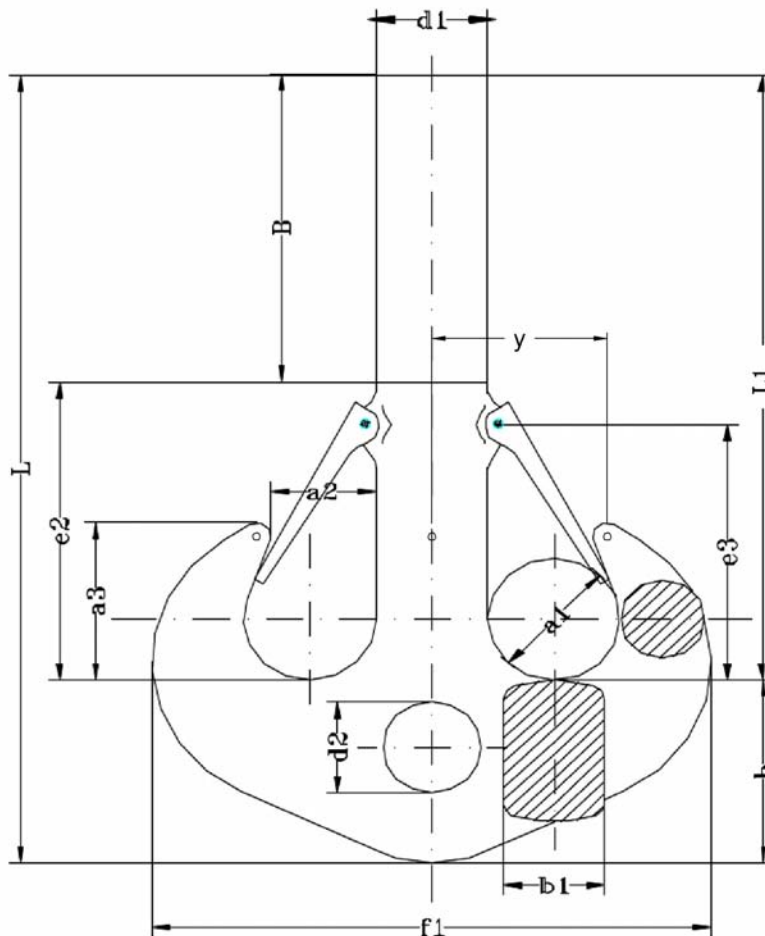

Model Number	Capacity Metric Tons Carbon Class P	Capacity Metric Tons Alloy Class T	Capacity Metric Tons Super Alloy Class V	a1	a2	a3	B	b1	d1	d2	e2	e3	f1	H	L	L1	y	Weight Kg.
GDB 10	20	32	40	90	71	116	220	75	75	74	230	192	377	130	580	450	117.5	41
GDB 12	25	40	50	100	80	130	258	85	85	78	252	210	421	150	660	510	132.5	57
GDB 16	32	50	63	112	90	146	296	95	95	86	284	237	471	170	750	580	148.5	82
GDB 20	40	63	80	125	100	163	332	106	106	96	318	265	531	190	840	650	165.5	115
GDB 25	50	80	100	140	112	182	347	118	118	106	378	315	598	212	927	715	185	160
GDB 32	63	100	125	160	125	205	388	132	132	116	402	335	672	236	1026	790	207	229
GDB 40	80	125	160	180	140	230	435	150	150	131	450	375	754	265	1150	885	233	330
GDB 50	100	160	200	200	160	260	461	170	170	146	504	420	842	300	1265	965	265	458
GDB 63	125	200	250	224	180	292	538	190	190	168	552	460	944	335	1425	1090	297	638
GDB 80	160	250	320	250	200	325	617	212	212	188	618	515	1062	375	1610	1235	331	892
GDB 100	200	320	400	280	224	364	685	235	235	208	690	575	1186	425	1800	1375	370	1248
GDB 125	250	400	500	315	250	408	776	265	265	235	774	645	1330	475	2025	1550	414.5	1757

•Dimensions are in millimeters •Tolerance on all dimensions, +7/-0 %

FORGED EYE HOOKS- DIN 7540 GRADE 80

Din 7540 Grade 80 Eye Hooks



DIN is the German Institute for Standardization (Deutsches Institut für Normung) and has been based in Berlin since 1917. DIN has historically developed the detailed and exacting standards used in German engineering and is the body that represents Germany in international standards organizations.

- Forged from high-strength alloy steel 34CrNiMo6V
- Model numbers 34-37 are drop forged- 38 and larger, hammer forged.
- Safe Working Loads from 40 to 400 metric tons
- Design factor 4:1 to ultimate strength
- Proof load is 2.5 times Safe Working Load
- Includes safety latch
- ROV modification (addition of pad eyes) available
- Higher load capacities available upon request

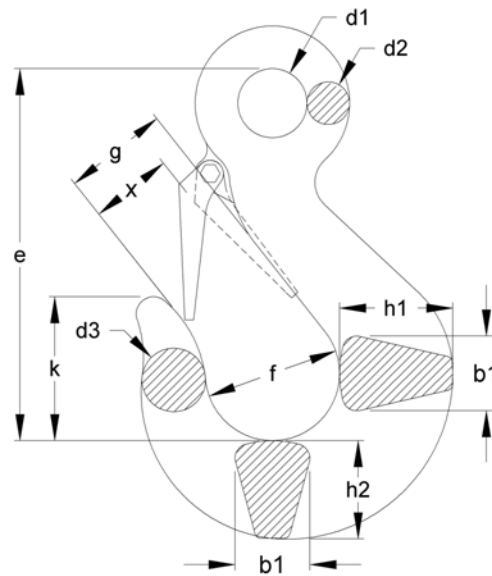

Model Number	Capacity (SWL) Metric Tons	MBL ton	b1	d1	d1 Tolerance	d2	d3	e	f	g	h1	h2	k	x	Weight Kg.
EH34	40	160	78	72	+1.9/-3.7	44	66	388	140	109	118	103	80	90	31.5
EH35	50	200	89	84	+1.9/-3.7	50	74	442	158	124	135	116	90	103	46
EH36	63	250	99	90	+2.3/-4.7	56	83	494	176	138	151	130	101	114	63
EH37	80	320	110	102	+2.3/-4.7	63	93	610	198	155	168	145	113	131	80
EH38	100	400	125	116	± 5.0	74	120	650	225	175	195	172	133	*	125
EH39	150	600	140	130	± 6.5	86	140	765	250	200	225	199	160	*	250
EH40	200	800	160	150	± 7.5	102	161	850	275	225	260	237	195	*	365
EH41	250	1000	180	170	± 8.5	120	195	928	310	255	290	269	210	*	515
EH42	300	1200	200	190	± 9.5	140	223	1052	350	290	330	310	240	*	730
EH43	400	1600	240	210	± 10.5	170	240	1195	400	320	380	345	270	*	1055

- Except where otherwise noted, dimensional tolerances for hooks through model EH37 are approximately ±5%, and increase somewhat for hooks larger than model EH37. Contact Miller for detailed tolerance data.
- Load capacities indicated are for operating temperatures between -40°C and 200°C. Outside this range check with Miller for reduced capacity limits.
- Dimensions are in millimeters.
- * x dimension for hammer forged hooks, please inquire.

FORGED HOOKS- HEAVY DUTY SHACKLE EYE HOOK

Heavy Duty Eye Hooks for Shackles

Miller Heavy Duty Eye Hooks are specifically intended for use with shackles or other pin-type connections. The cylindrical cross-section of the eye assures uniform pin loading while limiting relative hook motion.

Based also the DIN norms, they are typically forged from the strongest DIN "V" material class (see above) and carry a 5:1 design safety factor and a positive locking latch.

Adaptable for ROV (Remotely Operated Vehicles) use, these eye hooks fit standard shackles and also are available in customized versions.

Deformation indicators are also included on these heavy duty models.

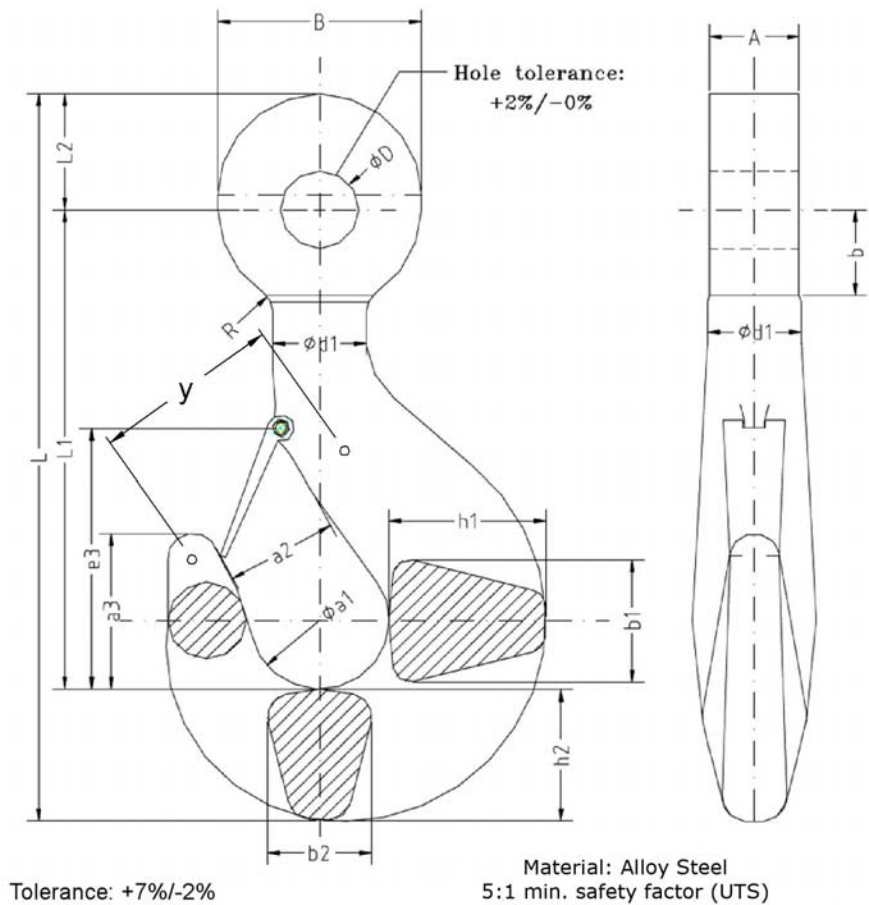

Model Number	Capacity (SWL) Metric Tons	A	a1	a2	a3	B	b1	b2	bb	D	d1	e3	h1	h2	L1	L2	L min	y	Weight Kg.
GSOJ8T	30	52.00	100	80	113	115	90	75	51	43.00	67	210	112	95	419	65	569	145	17
GSOJ8V	40	65.00	100	80	113	140	90	75	59	52.50	67	210	112	95	427	80	602	145	24
GSOJ12V	55	74.50	125	100	143	155	112	95	68	60.50	85	252	140	118	484	90	692	180	55
GSOJ20V	85	96.50	160	125	180	195	140	118	80	73.00	106	330	180	150	585	112	847	225	112
GSOJ25V	120	119.00	180	140	202	235	160	132	91	86.00	118	360	200	170	646	135	951	255	160
GSOJ32V	150	125.00	200	160	225	250	180	150	112	98.50	132	400	224	190	722	145	1057	290	220
GSOJ40T	175	131.50	224	180	252	285	200	170	126	109.50	150	447	250	212	793	165	1170	320	310
GSOJ40V	200	144.50	224	180	252	320	200	170	147	122.50	150	447	250	212	814	185	1211	320	310
GSOJ50V	250	179.00	250	200	285	340	224	190	168	135.00	170	485	280	236	903	195	1334	355	430
GSOJ63V	300	179.00	280	224	320	405	250	212	168	154.00	190	550	315	265	978	235	1478	400	600
GSOJ80V	400	201.50	315	250	358	460	280	236	196	179.50	212	598	355	300	1098	265	1663	450	860

•Dimensions are in millimeters •Tolerance on all dimensions, +7/-0 %